

DETAIL C
SCALE 1 : 10

DETAIL D
SCALE 1 : 10

Please Note
 Guard fencing needs to be erected on both sides of the cattle grid to prevent encroachment by animals and also to position vehicles correctly on the approach to the grid.

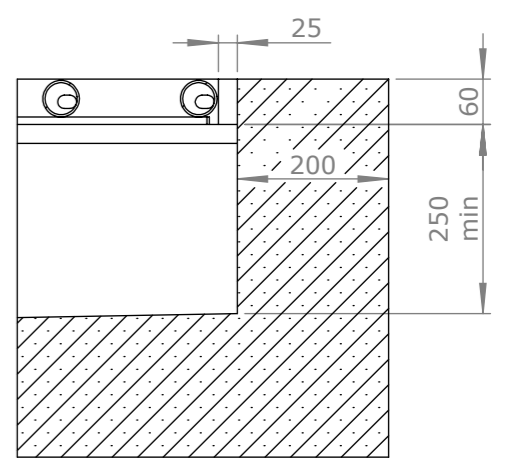
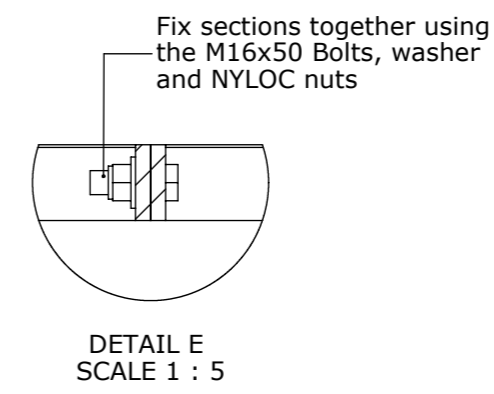

DETAIL E
SCALE 1 : 5

DETAIL F
SCALE 1 : 10

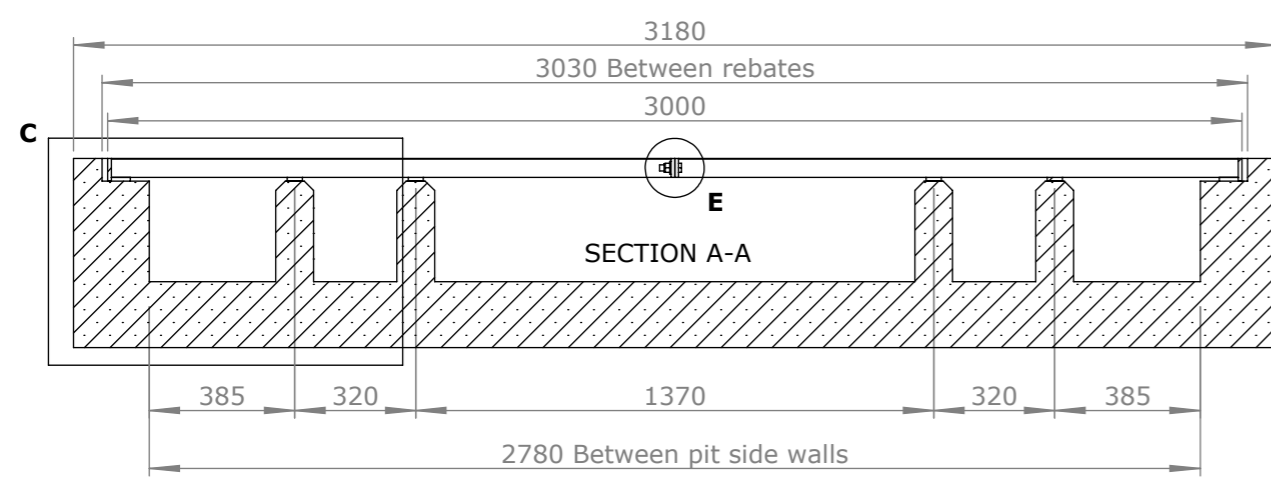

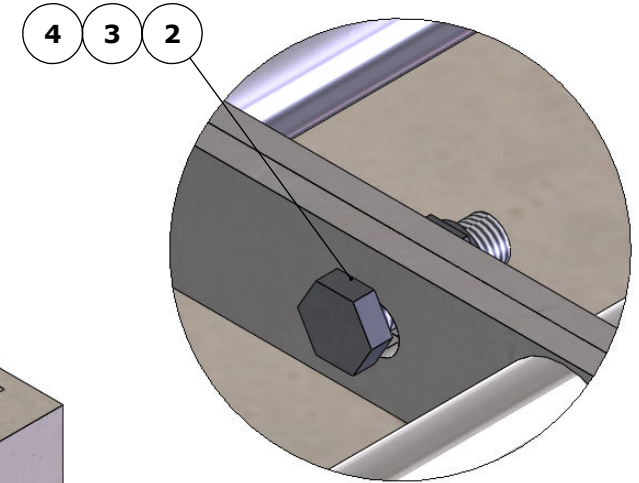
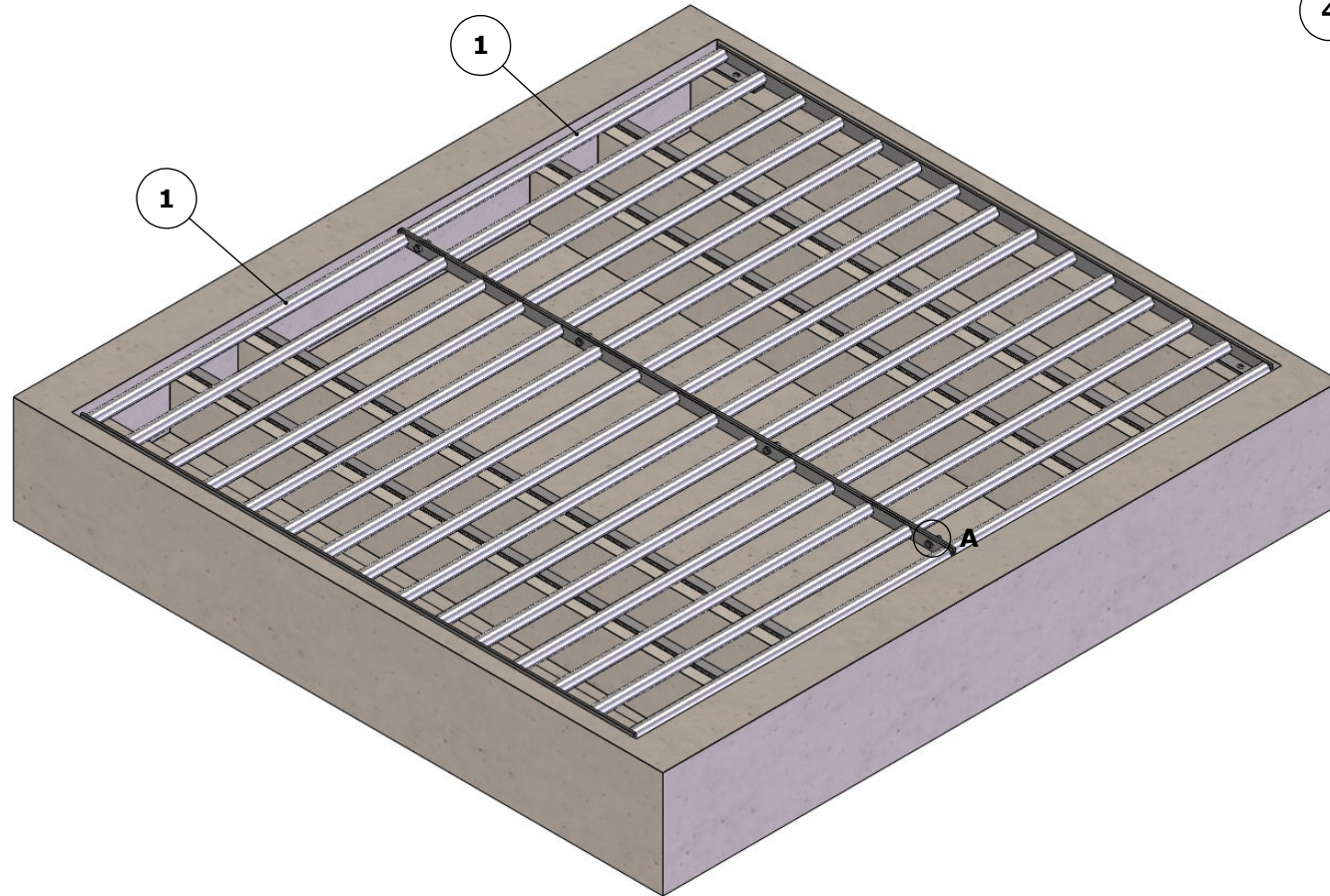

DETAIL A
SCALE 1 : 2

4	M16 NYLOC NUT TYPE T GLV	B040 2002 16	4
3	M16 WASHER FORM F GALV	B041 2006 16	4
2	M16 X 50 HIGH TENSILE SETSCREW GALV	B002 2160 50	4
1	1500 W X 2600 D SECTION OF 10 T C/GRID	F080 2010 11	2
REF NO.	DESCRIPTION	PART NUMBER	QTY.
TITLE	10 TONNE CATTLE GRID ASSEMBLY COMP OF		